

# User Manual

## Incremental

## Sensor Plugs

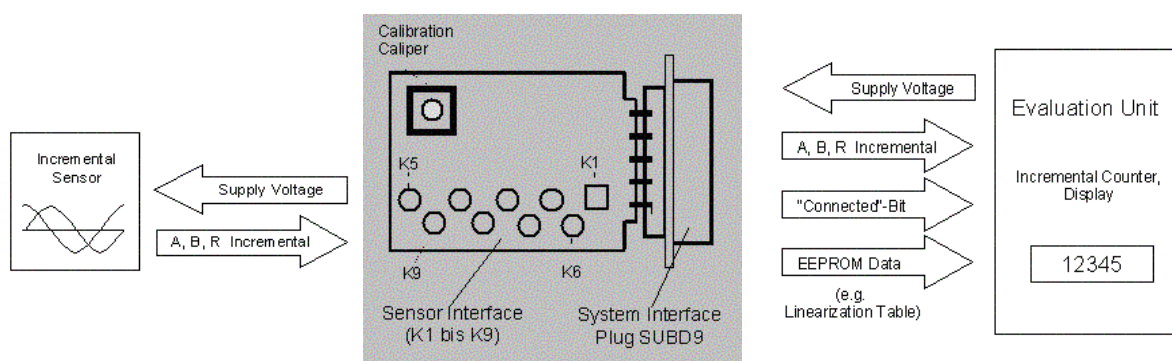

### Measuring and Controlling with components from DOLI

## DOLI Elektronik GmbH

---

<b>Corporate Name:</b>	DOLI Elektronik GmbH
<b>Headquarters:</b>	Adi-Maislinger-Straße 7, 81373 München, Deutschland ☎ (+49)-089-20 243-0 Fax (+49)-089-20 243 243 E-Mail info@doli.de
<b>Production:</b>	Ulmer Straße 34, 89584 Ehingen, Deutschland ☎ (+49)-07391-58039-0 Fax (+49)-07391-58039-71 E-Mail ehi@doli.de
<b>Sales:</b>	Mühlstr. 26, 55271 Stackeden-Elsheim, Deutschland ☎ (+49)-06130-944250 Fax (+49)-06130-944251 E-Mail sales@doli.de
<b>Internet:</b>	<a href="http://www.doli.de">www.doli.de</a>

## Table of Contents

<b>1</b>	<b>SAFETY HINTS</b> .....	<b>4</b>
1.1	General safety hints .....	4
1.1.1	Warning signs and hints .....	4
1.1.2	Demands on personnel .....	4
1.2	CE-Conformity, directions and standards .....	5
1.3	Specified normal operation .....	5
1.4	Environmental conditions .....	6
1.5	Guaranteeing an optimal EMV-Shielding .....	6
<b>2</b>	<b>SGS-SENSOR PLUGS FROM DOLI</b> .....	<b>7</b>
2.1	General description .....	7
2.2	Advantages .....	7
2.3	Safety: Supervision of the „Connected“-Bit (/CON-Bit) .....	7
2.4	Mechanical construction shapes .....	8
<b>3</b>	<b>ASSEMBLY INSTRUCTION FOR THE SENSOR PLUG</b> .....	<b>9</b>
3.1	Choosing the right sensor plug .....	9
3.2	Assembly of the SGS sensor plug to the cable of the transducer .....	10
3.3	Trouble shooting for malfunctions .....	12
<b>4</b>	<b>FUNCTIONS OF THE INCREMENTAL SENSOR PLUGS</b> .....	<b>12</b>
4.1	System interface (SUBD-9 and SUBD-37) .....	14
4.2	Sensor interfaces .....	15
4.2.1	Sensor plugs for sensors supplying TTL-level (rectangle) .....	15
4.2.2	Sensor plugs for sensors supplying RS422-difference-levels (rectangle) .....	16
4.2.3	Sensor plugs for sensors supplying 11µA-difference-level (sine) .....	17
4.2.4	Sensor plugs for sensors supplying 1 V <sub>ss</sub> –difference-level (sine) .....	18
<b>5</b>	<b>APPENDIX</b> .....	<b>19</b>
5.1	Order numbers .....	19
5.2	"Old" construction shapes .....	20
5.2.1	Complete componentries 9IS, 7IS1, 7IS2 and 9ISU, 7ISU1, 7ISU2 .....	20
5.2.2	Electronic componentries (SIT, SIL, SIS and SISU) .....	20
5.2.2.1	SIS-2349 and SISU-2350 .....	21
5.2.2.2	SIS-2174 and SISU-2199 .....	21
5.2.2.3	SIS-1670 and SISU-1765 .....	21
5.2.2.4	SIS-0922 and SISU-1198 .....	22
5.2.3	SIT-0791, SIL-0784 and SIS-0785 .....	22

## 1 Safety hints

### 1.1 General safety hints

Read this manual carefully before starting with the installation and operation of the device. False handling of the instrument / Componentry can cause severe damage to persons and property. It is essential to adhere to the technical directions and connection conditions from the name plate and documentations.

#### 1.1.1 Warning signs and hints

This manual contains several symbols, that will allow you to find your way more easily. Furthermore, the manual contains warning signs adverting to possibly dangerous situations. These warning signs may be found on the instrument, too. It is essential to adhere to the warning signs and the related hints:

Table 1: Symbols and their meanings

Symbol	Meaning
	<b>Safety Instructions:</b> In order to avoid interruptions in the work flow as well as damages to man and machine, follow the safety instructions at all cost.
	<b>Safety Instructions: Danger by electricity and its effects</b> In order to avoid interruptions in the work flow as well as damages to man and machine, follow the safety instructions at all cost.
	<b>Job/work instructions:</b> Instructive part of the document with precise work instructions Here you are asked to do something.
	<b>Information:</b> General information and descriptions of working procedures, etc.
	<b>Note:</b> Important note for the operation, the function or for the working procedures.
	<b>Tip:</b> Gives tips for easy handling of the device.





#### 1.1.2 Demands on personnel



**Attention! Only qualified personnel are allowed to perform transport, mounting, installation, start-up, operation or maintenance.**

Qualified personnel are people being well acquainted with transport, mounting, installation, start-up, operation or maintenance. These people must be adequately qualified for their occupations. In detail:

- Transport: Personnel skilled in treating componentries being susceptible to electrical discharge, only!
- Installation: Personnel with electro-technical apprenticeship, only!
- Start-up: Personnel with wide-ranged skills in the fields of electrotechnics and/or drive engineering, only!
- The qualified personnel must know and adhere to the following standards and directions:  
IEC 364 respectively CENELEC HD 384 or DIN VDE 0100  
National accident prevention directives or VBG 4

-  **Attention!** The devices do contain componentries being susceptible to electrical discharge. These componentries may be damaged by incorrect treatment. Always wear an earth strap to dissipate any electrostatic body charge before handling any instrumentation. Avoid the contact with highly insulating material (synthetic fibres, synthetic foils etc.). Place all units on a conductive base mat.
-  **Attention!** Do not open the devices! Keep all coverings closed during operation. There is danger of dead or severe damage to persons or property.
-  **Attention!** Draw the mains plug before opening the covering of the devices. There is danger of dead or severe damage to persons or property.
-  **Attention!** Never disconnect any electrical connection while the device is still energized. In bad cases, electric arcs may emerge and damage persons or property.
-  **Attention!** After having drawn the mains plug, wait at least two minutes before touching potentially live componentries (e.g. contacts, thread bolts) or disconnecting any electrical connection. After disconnection of the supply voltage, capacitors may bear dangerous voltages for up to two minutes. For your safety, it is recommended to measure the voltage in the link and wait, until it has fallen below 40V.

## 1.2 CE-Conformity, directions and standards

DOLI instrumentation is suitable for use with electrical systems or testing instruments.

After installation with a testing instrument, the system must not be used until compliance with the EC Machinery Directive 89/392/EEC (respectively 98/37/EC and future 2006/42/EC) has been confirmed. EN 60204 and EN 292-2 standards must also be adhered to.

EC Machinery Directive (98/37/EC) and future (2006/42/EC): The device meets the instructions of the EC Machinery Directive.

Low Voltage Directive (73/23/EEC): DOLI instrumentation is manufactured in accordance with the Low Voltage Directive 73/23/EEC, and the co-ordinated standards prEN 50178 in connection with EN 60204.

EMC-Directive (89/336/EEC) and (2004/108/EC): Under observance of the installation instructions of this documentation, we herewith declare the meeting of the objectives of the EMC Law (EMCG) for facilities and instruments with the following standards (in correspondence with the EMV-Directive 89/336/EEC and 2004/108/EC):

EN 50082-2 of 12.1994 (generic specification interference immunity, industry), EN 50081-1 of 08.1993 (generic specification emission, industry), IEC 801-2 of 01.1991, IEC 801-4 of 09.1987, EN 55011 of 03.1991.

The EC directive (2002/95/EC) is used for our appliances, also.

Regarding the safety of machines, the following standards are met:

DIN EN 292, DIN EN 294 part 1...4, DIN prEN 954 part 1, DIN EN 418 of 01.93, DIN EN 349 of 08.90, DIN VDE 0160 of 05.88, DIN EN 50081 part 2, DIN prEN 50082 part 2, DIN 51233 of 11.91, VW 11.062 of 10.87

In this documentation, you will find instructions for the EMC-compatible installation, such as shielding, grounding, manipulation of plugs and laying of wires.

Observe national rules for prevention of accidents or VBG-4.

The instrument manufacturer, testing instruments manufacturer/modifier and commissioning engineer are responsible for ensuring that their content conforms to all relevant electrical and safety standards.

## 1.3 Specified normal operation

The sensor plugs are electronical componentries designed to be used with measuring sensors.

Operate the device with the allowed power supply systems and under the allowed environmental conditions,

only! Adhere to the instructions given in this manual.

A start-up of the instrument (i.e. the specified normal operation) is allowed for compliance with the EMC directive (89/336/EEC), only. The appliances meet the requirements of the EC Low Voltage Directive (73/23/EEC).



**Attention! Inappropriate handling of the device may affect its functionality or cause severe damage to persons or property.**



**Attention! EMV-Directive (89/336/EEC) and EC-Low Voltage Directive 73/23/EEC must have been fully conformed to, before a system is handed over to a client after commissioning.**

### 1.4 Environmental conditions

Environmental temperature during operation: 0 to 50°C

The incremental sensor plug is an electrical device that has to be protected from aggressive environmental influences like temperatures above 80°C, short circuit, overvoltage etc.

### 1.5 Guaranteeing an optimal EMV-Shielding



**Attention! Use shielded cables every time. Connect the cable shield on both ends of the cable to the housing of the plugs and the appliances!**

## 2 SGS-Sensor Plugs from DOLI

### 2.1 General description

SGS sensor plugs have been designed to connect measurement transducers to the EDC controllers from DOLI. They do consist of a housing with an optimum EMV-shielding, an electronic componentry with sensor interface, signal conditioning and a connector for the EDC, as well as an EEPROM for the storage of the calibration data and the physical unit of the transducer. Upon switch-on, the EDC reads out these data automatically and it adapts itself to them.

### 2.2 Advantages

1. The calibration data of a connected transducer will be read out automatically upon switch-on of the EDC.
2. The transducer is defined completely via the sensor plug.
3. Transducers can be mass-produced and calibrated. Via the sensor plug, they can be used immediately on each EDC.
4. If a transducer is defective, it can easily be exchanged by a new one: The new transducer just has to be calibrated in-house and then sent to the customer.
5. If the EDC is defective, just the EDC has to be exchanged. The transducer can be used further on as there is no need to change its calibration.
6. The EEPROM can be used not only to store calibration data, but also production data, company relevant data aso.

### 2.3 Safety: Supervision of the „Connected“-Bit (/CON-Bit)

In the EDC firmware, the existence of a transducer is supervised by a „Connected“-Bit (/CON-Bit). This enables the software e.g. to prevent the engagement of the drive, if there is no position transducer connected to the system.



**Note:** This supervision is not a 100% guarantee.

Please find some examples causing the system to recognize a transducer as „connected“, though the transducer does not function in a correct manner:

- The cable connecting the transducer may be defective.
- The transducer may be defective.
- The /CON-Bit input may be defective.

## 2.4 Mechanical construction shapes

Three different construction shapes are available for incremental sensor plugs: one channel at the SUBD-9-plug, one channel at the SUBD-37-socket and two channels at the SUBD-37-socket.

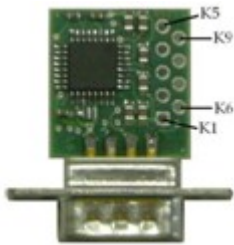

Fig. 1: Sensor plug with SUBD-9-plug, one incremental channel.

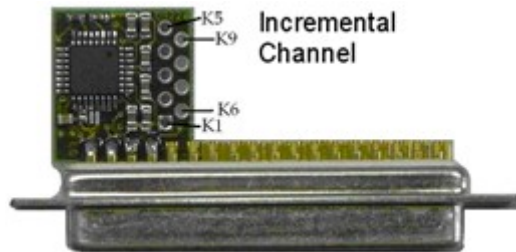

Fig. 2: Sensor plug with SUBD-37-socket, one incremental channel.

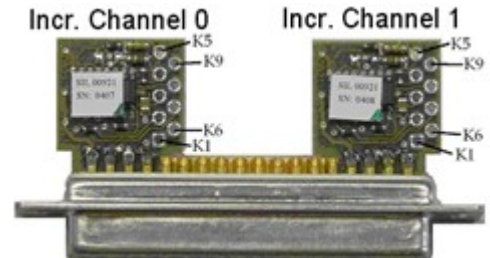

Fig. 3: Sensor plug with SUBD-37-socket, two incremental channels.

Sensor plugs:

SGS\_9IT ,  
 SGS\_9IL ,  
 SGS\_9IS ,  
 SGS\_9ISU

Sensor plugs:

SGS\_7IT1 ,  
 SGS\_7IL1 ,  
 SGS\_7IS1 ,  
 SGS\_7ISU1

Sensor plugs:

SGS\_7IT2 ,  
 SGS\_7IL2 ,  
 SGS\_7IS2 ,  
 SGS\_7ISU2

## 3 Assembly instruction for the sensor plug

### 3.1 Choosing the right sensor plug

Incremental transducers (e.g. shaft encoders, linear scales) are provided by different producers. They do differ from each other by different parameters, such as e.g. supply voltage, increments per count, signal shape (sine or rectangle), signal level and so on.

When choosing a sensor plug, you will have to check, whether the attributes of the sensor plug do fit to the technical data of the transducer.



**Note:** When choosing a sensor plug for your transducer, you must take the signal level and the construction shape of the plug into account. You will find these data in the technical sheets of the transducer and the controller.

Signal level of the transducer: rectangle-TTL, rectangle-RS422, sine-11µA, sine-1Vss

Construction shape of the plug: 9-pin or 37-pin

The following table provides a first overview of the allocation of sensor plugs to the interfaces of the system. For further informationen about the allocation of the sensor plugs, pleas see chapter 4.2.

*List 2: Allocation of incremental sensor plugs to the system interfaces*

System interface	Rectangle-TTL	Rectangle-RS422	Sine-11µA	Sine-1Vss
SUBD-9-pin	SGS_9IT (0793)	SGS_9IL (0792)	SGS_9IS (2360)	SGS_9ISU (2363)
SUBD-37-pin (1 channel)	SGS_7IT1 (0797)	SGS_7IL1 (0795)	SGS_7IS1 (2361)	SGS_7ISU1 (2364)
SUBD-37-pin (2 channel)	SGS_7IT2 (0798)	SGS_7IL2 (0796)	SGS_7IS2 (2362)	SGS_7ISU2 (2365)

## 3.2 Assembly of the SGS sensor plug to the cable of the transducer

### 1. Open the plug case.

Unscrew the fixing screws for the lid (for 37-pin plug only, see Fig. 4), put the screw driver into the lateral slits and unlock the lid by carefully turning the screw driver. Remove the lid.

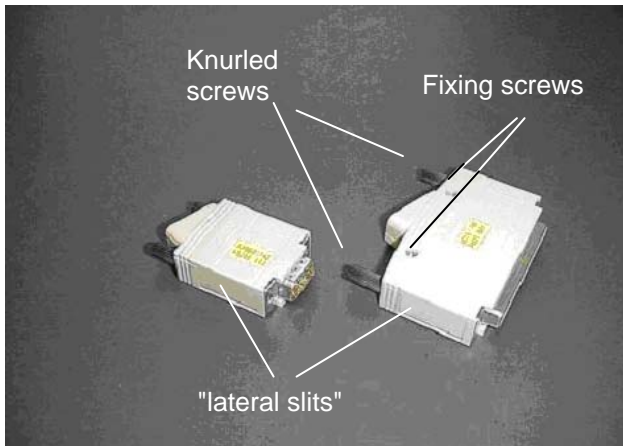

Fig. 4: SGS-Sensor plug. 9-pin and 37-pin case.

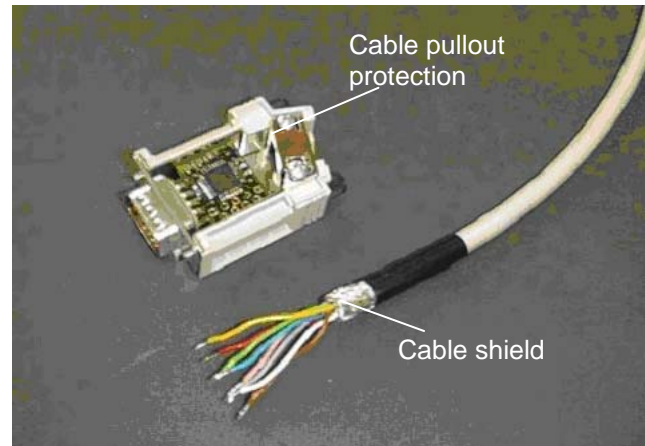

Fig. 5: Case open, transducer cable prepared for assembly.

### 2. Prepare the cables as shown in Fig. 5:

Dismantle the cable, uncover the shield and remove the isolation of the leads.

### 3. Screw the cable into the pullout-protection as described here:

Remove the cable-pullout-protection from the case (pull it upwards). Loosen the screws and insert the cable into the pullout-protection.



**Attention! Be sure to create a large-surface electrical connection between the cable shield and the pullout-protection!**

Fix the screws of the pullout-protection.

### 4. For sine sensor plugs only (for soldering of the leads, see step 5):

Choose the wanted interpolation factor (25 or 50) by connecting the right solder bridges. Make sure, that the maximum input frequency (sine 50kHz) will be kept and that the maximum output frequency can be processed by the following appliance.

**Example: Setting the interpolation factor for SGS\_9IS (2360, sine 11µA) and SGS\_9ISU (2363, sine 1V):**

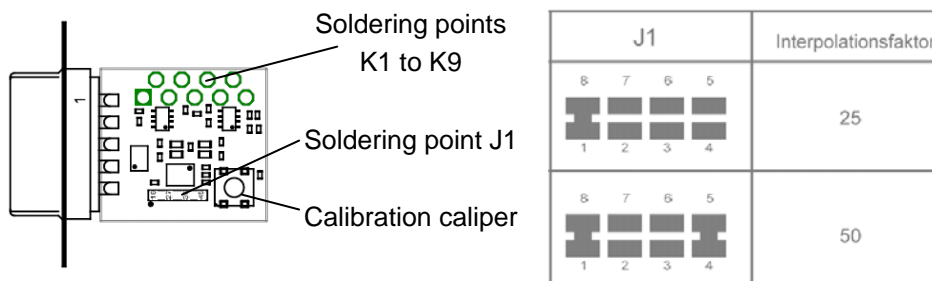

Fig. 6: Draft of the electronic componentry, connection of the soldering bridges for the interpolation factors 25 and 50.



**Note: The electronic componentry of the 37-pin plug looks alike.**

## 5. Solder the leads of the cable to the electronic componentry of the plug:

Draw back the knurled screws as far as possible and remove the electronic componentry (connector and sensor interface) from the case.

Lead the cable to the opposite side of the calibration caliper in order to avoid a contact between the two (see Fig. 6 draft electronic componentry) and solder the leads to the soldering points K1 to K9 of the sensor interface. See Fig. 7 for the configuration of the soldering points of the sensor plugs depending on the signal type.



**Note:** Use acid-free flux only for soldering the sensor cable to the sensor plug.

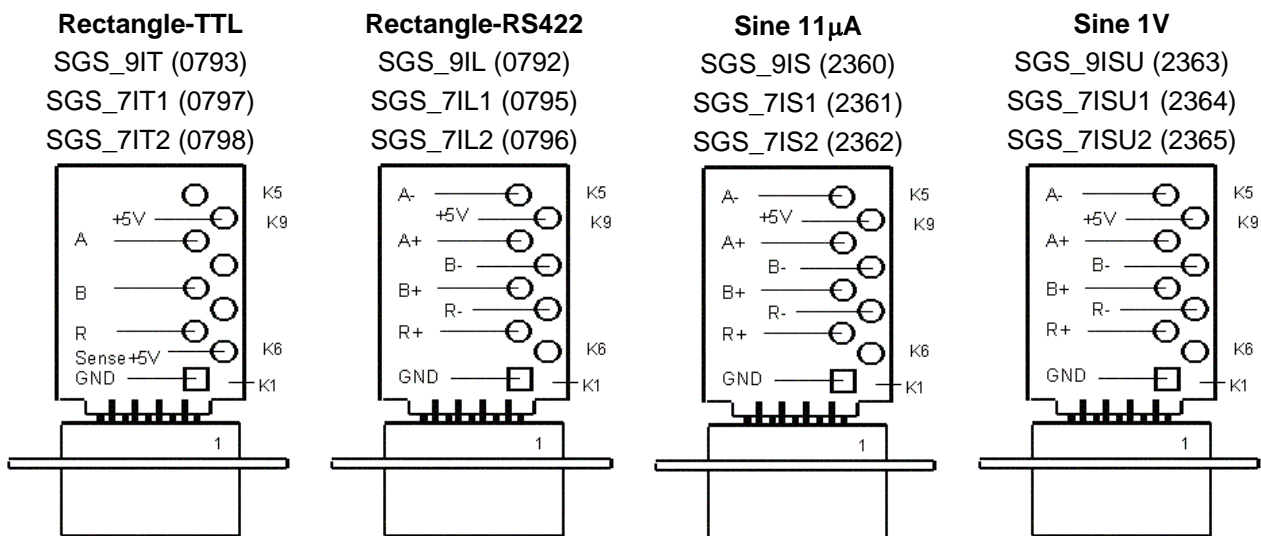

Fig. 7: Configuration of the soldering points for 9-pin and 37-pin sensor plugs depending on the signal type.

See appendix for the configuration of componentries with **old mechanical construction shapes**.

## 6. Check the solder points.

Check the solder points. Remove salient strands in order to prevent short circuits with the plug case.

## 7. Reassemble the plug.

Insert the electronic componentry (calibration caliper downwards) and the cable-pullout-protection into the case and fix the pullout-protection with the screws (see Fig. 8). Place the lid on the case and click it into place.

For 37-pin cases only: Screw down the fixing screws for the lid.

## 8. Write the transducer data into the sensor-EEPROM.

(See EDC installation manual for a description)

## 9. Done.



Fig. 8: Reassembled sensor plug, lid still open.

## 3.3 Trouble shooting for malfunctions

In case of malfunctions occurring after the assembly, please check the following points:

- Does the sensor plug fit for the transducer? (Signal type: sine/rectangle, interpolation factor, supply voltage)
- Has the transducer been connected in the correct manner?
- Are the soldering points o.k.? No short circuits?
- Is the cable shield connected to the plug case?
- Are the counting frequencies too high?
- Is the cable too long (inductive disturbance)?

## 4 Functions of the incremental sensor plugs

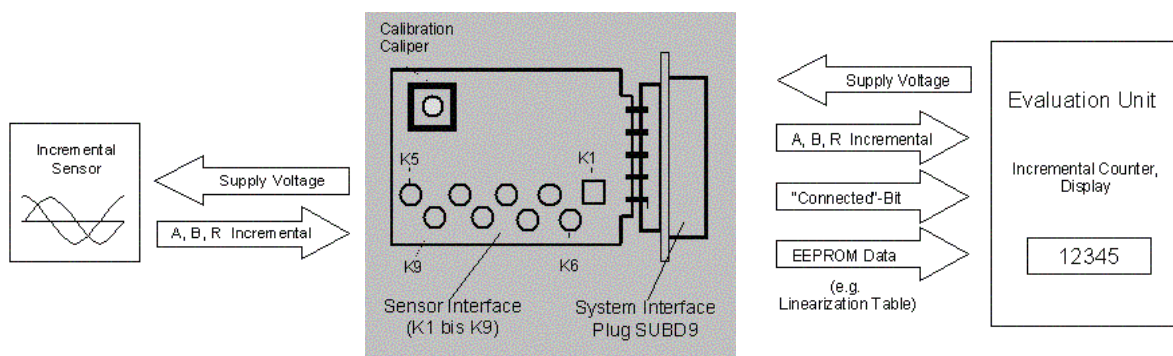

Fig. 9: Functional principle of the incremental sensor plugs.

Incremental sensor plugs are used to connect incremental transducers to incremental inputs of the DOLI measurement appliances. The incremental sensor plug offers the following functions:

List 3: Functions of the incremental sensor plugs.

Function	Remark
Sensor interface:	The sensor interface consists of the soldering points K1 to K9. The connection cable coming from the transducer has to be soldered here.
Level adaptation:	Adaptation for incremental sensors with the following signal levels: <ul style="list-style-type: none"> <li>• single TTL rectangle</li> <li>• level of the difference voltage RS422 rectangle</li> <li>• Difference current <math>11\mu A_{SS}</math> sine</li> <li>• Difference voltage <math>1V_{SS}</math> sine</li> </ul> The levels of the two measurement traces as well as the one of the reference trace (A, B, R) are processed.
Interpolation:	For sine signals only: <ul style="list-style-type: none"> <li>• The shifted sine impulses (A and B) are used to generate a multiplied number of rectangle impulses.</li> </ul>
„Connected“ Bit (/CON):	The condition of the „Connected-Bit“ tells the DOLI measurement appliance, whether a sensor is connected to the measurement input or not. The „Connected-Bit“ is generated using one of the following methods: <ul style="list-style-type: none"> <li>• <del>detected out of the supply current for the sensor *)</del></li> <li>• detected out of the measuring signal levels of the sensor</li> <li>• derived from the positive sense duct of the sensor</li> <li>• derived from the negative sense duct of the sensor</li> <li>• solder bridges in the sensor plug</li> </ul>

Sensor data:	<p>The „sensor data“ describe the features of the connected sensor. The sensor data are used to inform the DOLI appliances about these features e.g. the resolution of the connected sensor (number of marks).</p> <ul style="list-style-type: none"><li>• The sensor data are stored in an EEPROM in the sensor plug.</li></ul>
Calibration bit (/KE):	<p>The condition of the „calibration bit“ tells the DOLI appliance, whether an overwriting of the data in the sensor-EEPROM is admissible.</p> <ul style="list-style-type: none"><li>• Caliper on the sensor plug</li></ul>
System interface:	<p>The system interface supplies the DOLI appliances (e.g. EDC580, 4INC) with the processed signals in a standardized shape (TTL-level, plug type, pin description). The system interface consists of a 9-pin SUBD-plug or a 37-pin SUBD-socket. Sensor plugs having a 37-pin SUBD-socket can be equipped with one or two sensor channels.</p>

*\*) Producers of incremental sensors normally indicate the supply current as „typical“ or „maximum“. With this indication, a save recognition is not possible.*

## 4.1 System interface (SUBD-9 and SUBD-37)

List 4: Allocation of the pins of the SUBD-9 (left side) and the SUBD-37 interface (right side).

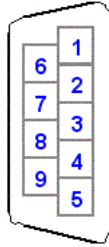

Pin	Signal
1	GND
6	/KE
2	/CON
7	I2C-Data
3	I2C-Clock
8	A
4	B
9	+5V
5	R

Plug

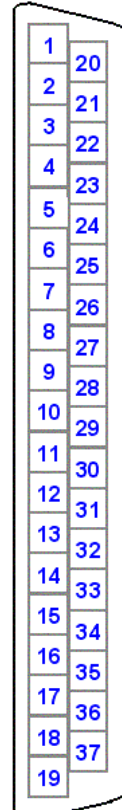

Pin	Signal
1	R
20	+5V
2	B Channel 0
21	A
3	I2C-Clock
22	I2C-Data
4	/CON
23	/KE
5	GND
24	
6	
25	
7	
26	
8	
27	
9	
28	
10	
29	
11	
30	
12	
31	
13	
32	
14	
33	
15	R
34	+5V
16	B Channel 1
35	A
17	I2C-Clock
36	I2C-Data
18	/CON
37	/KE
19	GND

Socket

The signals of the system interface have TTL-level.

### SUBD-37-Socket:

- The signals of both incremental inputs do seize 9 pins at the edges of the socket each.
- Incremental channel 0 is on pin 1, incremental channel 1 is on pin 19.
- The mid 19 pins (pin 6 to 14 and pin 24 to 33) are free for other IO-signals

### Connected-Bit (/CON):

In order to generate the signal „/CON“ e.g. for test purposes, this signal can be connected to GND using a solder bridge directly at the system interface.

### Componentries with a 9-pin sensor interface:

- EDC580/222/220, EDC60/120, EDC5/25/100

### Componentries with a 37-pin sensor interface:

- 4INC, 2INC, 4SSI

## 4.2 Sensor interfaces

As described in chapter 3.2, the connection cable of the transducer is soldered to the soldering points K1 to K9 of the sensor plug. The cable shield is connected to the case via the cable-pullout-protection. The following chapters show you how to choose the right sensor plug for your transducer and how to allocate the signals in a correct manner.

### 4.2.1 Sensor plugs for sensors supplying TTL-level (rectangle)

The sensor plugs SGS\_9IT (0793), SGS\_7IT1 (0797) and SGS\_7IT2 (0798) fit for transducers supplying rectangle signals with TTL-outputs.

*List 5: Functions of sensor plugs for transducers with rectangle signals and TTL-level.*

Function	Description
Voltage sply:	The incremental transducer is supplied via the soldering points K1 (GND) and K9 (+5V, max. 250mA).
Measuring signals:	For the measuring signals „A“ and „B“, signals with TTL-level are expected.
Reference signal:	For the reference signal respectively the index signal „R“, one signal with TTL-level is expected, too.
„Connected“-Bit:	For the generation of the „Connected“-Bit /CON, the sense duct of the positive voltage supply „+Sense“ has to be soldered to the connetion points K6. For test purposes, the „/CON“-signal can be generated by bypassing /CON with GND.



**Note:** Signal conduction via cables is followed by several disturbances (as e.g. leaking signals, inductive disturbances or overshooting), that may cause malfunctions up to the destruction of the appliance.  
Especially TTL-signals are very susceptible. Therefore, incremental sensors supplying TTL-signals should be connected with short cables (<50cm) only.

Maximum frequency of the input signals:

The maximum frequency of the sensors can be found in the technical description from the producer.

Maximum frequency of the output signals:

$$f_{OUT} = f_{IN}$$

The actual maximum output frequency must not overceed the allowed input frequency of the downstream evaluation unit (in the best case: 10MHz).

*List 6: Allocation of the signals to the soldering points (TTL-level).*

Kontakt	Signal
K1	GND
K2	R
K3	B
K4	A
K5	
K6	+Sense (5V)
K7	
K8	
K9	Supply: +5V

For the generation of the „Connected“-Bit, the signal "+Sense (5V)" (recirculation of the supply voltage of the sensor) is used.

## 4.2.2 Sensor plugs for sensors supplying RS422-difference-levels (rectangle)

The sensor plugs SGS\_9IL (0792), SGS\_7IL1 (0795) and SGS\_7IL2 (0796) fit for transducers supplying rectangle signals with difference outputs.

List 7: Functions of sensor plugs for transducers with rectangle signals and RS422-difference-level.

Function	Description
Voltage sply:	The incremental transducer is supplied via the soldering points K1 (GND) and K9 (+5V, max. 250mA) <del>or K6 (+5V, 10 to 60mA).</del>
Measuring signals:	For the measuring signals „A“ and „B“, difference signals with RS422-level are expected.
Reference signal:	For the reference signal respectively the index signal „R“, one difference signal with RS422-level is expected, too.
„Connected“-Bit:	<del>The „Connected-Bit“ /CON is generated by the sensor plug itself, as soon as the supply current to the connected sensor is higher than 50mA (connection to K9) resp. Higher than 10mA (connection to K6).</del> For test purposes, the „/CON“-signal can be generated by bypassing /CON with GND.



**Note:** Signal conduction via cables is followed by several disturbances (as e.g. leaking signals, inductive disturbances or overshooting), that may cause malfunctions up to the destruction of the appliance.  
A wide spread method for a safe signal transduction via a cable length of up to 1,000m is the usage of line drivers and line receivers following the RS422-Industry-Standard.

Maximum frequency of the input signals: 10MHz  
The maximum frequency of the sensors can be found in the technical description from the producer.

Frequency of the output signals:  $f_{OUT} = f_{IN}$   
The actual maximum output frequency must not overceed the allowed input frequency of the downstream evaluation unit (in the best case: 10MHz).

List 8: Allocation of the signals to the soldering points (RS422-difference-level).

Kontakt	Signal
K1	GND
K2	R+
K3	B+
K4	A+
K5	A-
K6	Supply 2: +5V 10-60mA
K7	R-
K8	B-
K9	Supply 1: +5V 250mA max

RS422: Difference signals linedriver/linereceiver

~~The „Connected-Bit“ is generated by measuring and evaluating the sensor supply voltage.~~

~~The fitting supply (K6 or K9) has to be connected depending on the current consumption of the sensor.~~

## 4.2.3 Sensor plugs for sensors supplying 11µA-difference-level (sine)

The sensor plugs SGS\_9IS (2360), SGS\_7IS1 (2361) and SGS\_7IS2 (2362) fit for transducers supplying sine signals with a signal level of 11µA<sub>SS</sub>.

List 9: Functions of sensor plugs for transducers with sine signals and 11µA-difference-level.

Function	Description
Voltage supply:	The incremental transducer is supplied via the soldering points K1 (GND) and K9 (+5V, max. 250mA).
Measuring signals:	For the measuring signals „A“ and „B“, difference-current signals with a level of 11µA <sub>SS</sub> (6 to 16µA <sub>SS</sub> ) are expected.
Reference signal:	For the reference signal respectively the index signal „R“, one difference-current signal with a level of 6µA <sub>SS</sub> (3 to 8µA <sub>SS</sub> ) is expected.
„Connected“-Bit:	The „Connected-Bit“ /CON is generated by the sensor plug itself, as soon as the level of the measuring signals „A“ and „B“ is correct (in former days: as soon as the supply current to the connected sensor is higher than 25mA)  For test purposes, the „/CON“-signal can be generated by bypassing /CON with GND.



**Note:** Signal conduction via cables is followed by several disturbances (as e.g. leaking signals, inductive disturbances or overshooting), that may cause malfunctions up to the destruction of the appliance.  
For the transduction of difference-current signals with a level of 11µASS resp. 6µASS, a special cable must be used (low capacity, shielded, stranded in pairs).  
When using an optimum cable and signal frequencies lower than 50kHz, a maximum cable length of 30m is possible.

Maximum frequency of the input signals: 50kHz sine  
The maximum frequency of the sensors can be found in the technical description from the producer.

Maximum frequency of the output signals: 9MHz  
The actual maximum output frequency must not exceed the allowed input frequency of the downstream evaluation unit.

List 10: Allocation of the signals to the soldering points (11µA-difference-level).

Kontakt	Signal
K1	GND
K2	R+
K3	B+
K4	A+
K5	A-
K6	
K7	R-
K8	B-
K9	Supply: +5V

The interpolation factor (25 or 50) is chosen via soldering bridges on the printed board (see chapter 3 and chapter 5, also)  
The „Connected-Bit“ is generated by measuring and evaluating the sensor supply voltage (A+/A- and B+/B-).

## 4.2.4 Sensor plugs for sensors supplying 1 V<sub>SS</sub> –difference-level (sine)

The sensor plugs SGS\_9ISU (2363), SGS\_7ISU1 (2364) and SGS\_7ISU2 (2365) fit for transducers supplying sine signals with a signal level of 1V<sub>SS</sub>.

List 11: Functions of sensor plugs for transducers with sine signals with 1V<sub>SS</sub>-difference level.

Function	Description
Voltage supply:	The incremental transducer is supplied via the soldering points K1 (GND) and K9 (+5V, max. 125mA).
Measuring signals:	For the measuring signals „A“ and „B“, difference-voltage signals with a level of 1V <sub>SS</sub> (0.6 to 1.2V <sub>SS</sub> ) are expected.
Reference signal:	For the reference signal respectively the index signal „R“, one difference-voltage signal with a level of 0.5V <sub>SS</sub> (0.2 to 0.8V <sub>SS</sub> ) is expected.
„Connected“-Bit:	The „Connected-Bit“ /CON is generated by the sensor plug itself, as soon as the level of the measuring signals „A“ and „B“ is correct.  For test purposes, the „/CON“-signal can be generated by bypassing /CON with GND.



**Note:** Signal conduction via cables is followed by several disturbances (as e.g. leaking signals, inductive disturbances or overshooting), that may cause malfunctions up to the destruction of the appliance.  
For the transduction of difference-voltage signals with a level of 1V<sub>SS</sub>, a special cable must be used (low capacity, shielded, stranded in pairs). When using an optimum cable and signal frequencies lower than 50kHz, a maximum cable length of 30m is possible.

Maximum frequency of the input signals: 50kHz sine  
The maximum frequency of the sensors can be found in the technical description of the producer.

Maximum frequency of the output signals: 9MHz  
The actual maximum output frequency must not exceed the allowed input frequency of the downstream evaluation unit.

List 12: Allocation of the signals to the soldering points (1V<sub>SS</sub>-difference-level).

Kontakt	Signal
K1	GND
K2	R+
K3	B+
K4	A+
K5	A-
K6	
K7	R-
K8	B-
K9	Supply: +5V

The interpolation factor (25 or 50) is chosen via soldering bridges on the printed board (see chapter 3 and chapter 5, also).

The „Connected-Bit“ is generated by measuring and evaluating the sensor supply voltage (A+/A- and B+/B-).

## 5 Appendix

### 5.1 Order numbers

List 13: Order numbers and signal allocations of the sensor plugs with 9-pin case.

Sensor plug	Order no	Electronics	Level
SGS_9IT (9pin-Incremental-TTL)	0793	SIT-0920 (0791)	Rectangle TTL
SGS_9IL (9pin-Incremental-Linereceiver)	0792	SIL-0921 (0784)	Rectangle RS422
SGS_9IS (9pin-Incremental-Sine)	2360	SIS-2349	Sine 11uA
SGS_9ISU (9pinIncremental-Sine)	2363	SISU-2350	Sine 1V

List 14: Order numbers and signal allocations of the sensor plugs with 37-pin case.

Sensor plug	Order no	Electronic channel 0	Electronic channel 1	Level
SGS_7IT1 (37pin-Incremental-TTL-1x)	0797	0920 (0791)	-	Rectangle TTL
SGS_7IT2 (37pin-Incremental-TTL-2x)	0798	0920 (0791)	0920 (0791)	Rectangle TTL
SGS_7IL1 (37pin-Incremental-Linereceiver-1x)	0795	0921 (0784)	-	Rectangle RS422
SGS_7IL2 (37pin- Incremental-Linereceiver-2x)	0796	0921 (0784)	0921 (0784)	Rectangle RS422
SGS_7IS1 (37 pin -Incremental-Sine-1x)	2361	SIS-2349	-	Sine 11µA
SGS_7IS2 (37 pin -Incremental-Sine-2x)	2362	SIS-2349	SIS-2349	Sine 11µA
SGS_7ISU1 (37 pin -Incremental-Sine-1x)	2364	SISU-2350	-	Sine 1V
SGS_7ISU2 (37 pin -Incremental -Sine-2x)	2365	SISU-2350	SISU-2350	Sine 1V

## 5.2 "Old" construction shapes

### 5.2.1 Complete componentries 9IS, 7IS1, 7IS2 and 9ISU, 7ISU1, 7ISU2

List 15: Allocation of the old order numbers to the current sensor plugs (complete componentries) according to the signal level.

Input level	Sensor plug	Order number			
		current	precursor		
Sine 11 $\mu$ A	SGS_9IS	<b>2360</b>	2216	1762	0794
	SGS_7IS1	<b>2361</b>	2217	1763	0799
	SGS_7IS2	<b>2362</b>	2218	1764	0800
Sine 1V	SGS_9ISU	<b>2363</b>	2219	1766	1199
	SGS_7ISU1	<b>2364</b>	2220	1767	1200
	SGS_7ISU2	<b>2365</b>	2221	1768	1201

### 5.2.2 Electronic componentries (SIT, SIL, SIS and SISU)

List 16: Allocation of the old order numbers to the current electronic componentries according to the signal level.

Input level	Electronic componentry		Different electronic functions
	current	precursor	
TTL	SIT-0920	SIT-0791	Input signals A, B and R are directly soldered to the SUBD-plug
RS422	SIL-0921	SIL-0784	
Sine 11 $\mu$ A	SIS-2349	SIS-2174 SIS-1670 SIS-0922 SIS-0785	Generation of the "Connected-Bit" out of the supply current
Sine 1V	SISU-2350	SISU-2199 SISU-1765 SISU-1198	

## 5.2.2.1 SIS-2349 and SISU-2350

Current interpolator componentries (state 5/2010).

### Configuration:

Choose the wanted interpolation factor (25 or 50) by connecting the right soldering bridges (see chapter 3.2, also). Make sure, that the maximum input frequency (sine 50kHz) will be kept and that the maximum output frequency (9MHz) can be processed by the following appliance.

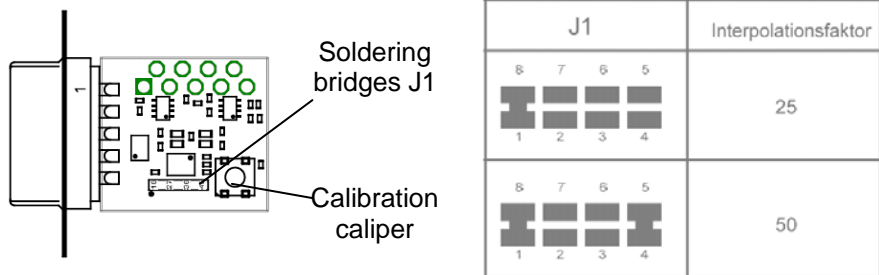

Fig. 10: Draft of the electronic componentry type SIS-2349 and SISU-2350; connection of the soldering bridges for the interpolation factors 25 and 50.

## 5.2.2.2 SIS-2174 and SISU-2199

The electronic device „RLX400“ is not available anymore. Therefore, it is not possible to produce these componentries any longer.

### Configuration:

Choose the wanted interpolation factor (5, 10, 20, 25 or 50) by connecting the right solder bridges (see chapter 3.2, also). Make sure, that the maximum input frequency (sine 50kHz) will be kept and that the maximum output frequency (9MHz) can be processed by the following appliance.

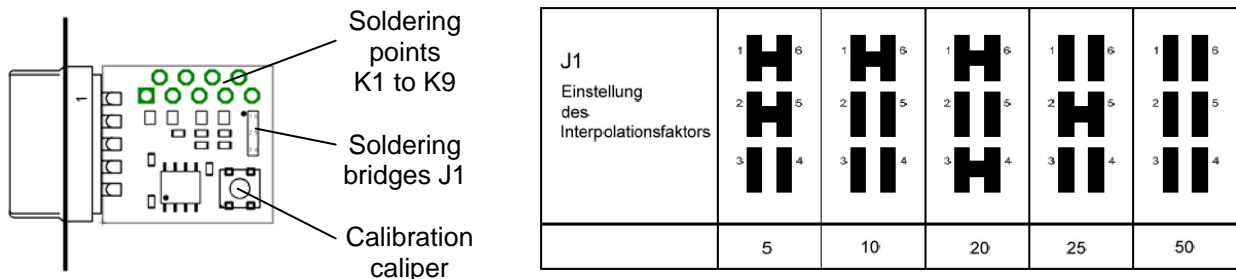

Fig. 11: Draft of the electronic componentry type SIS-2174 and SISU-2199; connection of the soldering bridges for the interpolation factors 5, 10, 20, 25 and 50.

## 5.2.2.3 SIS-1670 and SISU-1765

The electronic device „RLX100“ is not available anymore. Therefore, it is not possible to produce these componentries any longer.

### Configuration:

Choose the wanted interpolation factor 5, 10 or 25) by connecting the right solder bridges (see chapter 3.2, also).

Make sure, that the maximum input frequency (sine 50kHz) will be kept and that the maximum output frequency (9MHz) can be processed by the following appliance.

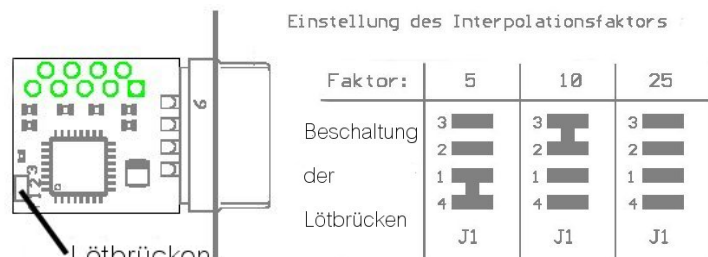

Fig. 12: Draft of the electronic componentry type SIS-1670 and SISU-1765; connection of the soldering bridges for the interpolation factors 5, 10 and 25.

## 5.2.2.4 SIS-0922 and SISU-1198

The electronic device „MIP200“ is not available anymore. Therefore, it is not possible to produce these components any longer.

### Configuration:

Choose the wanted interpolation factor (5, 10, 25 or 50) by connecting the right solder bridges (see chapter 3.2, also).

Make sure, that the maximum input frequency (sine 50kHz) will be kept and that the maximum output frequency (9MHz) can be processed by the following appliance.

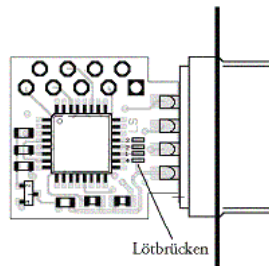

### Choice of the Interpolation Factor

Factor	5	10	25	50
Condition of the solder bridges	3 2 1 4	3 2 1 4	3 2 1 4	3 2 1 4

Fig. 13: Draft of the electronic componentry type SIS-0922 and SISU-1198; connection of the soldering bridges for the interpolation factors 5, 10, 25 and 50.

## 5.2.3 SIT-0791, SIL-0784 and SIS-0785

Some precursor series do differ from the current sensor plug series mainly by a different case. Hence, they have different dimensions and a deviant arrangement of the soldering points K1 to K9.

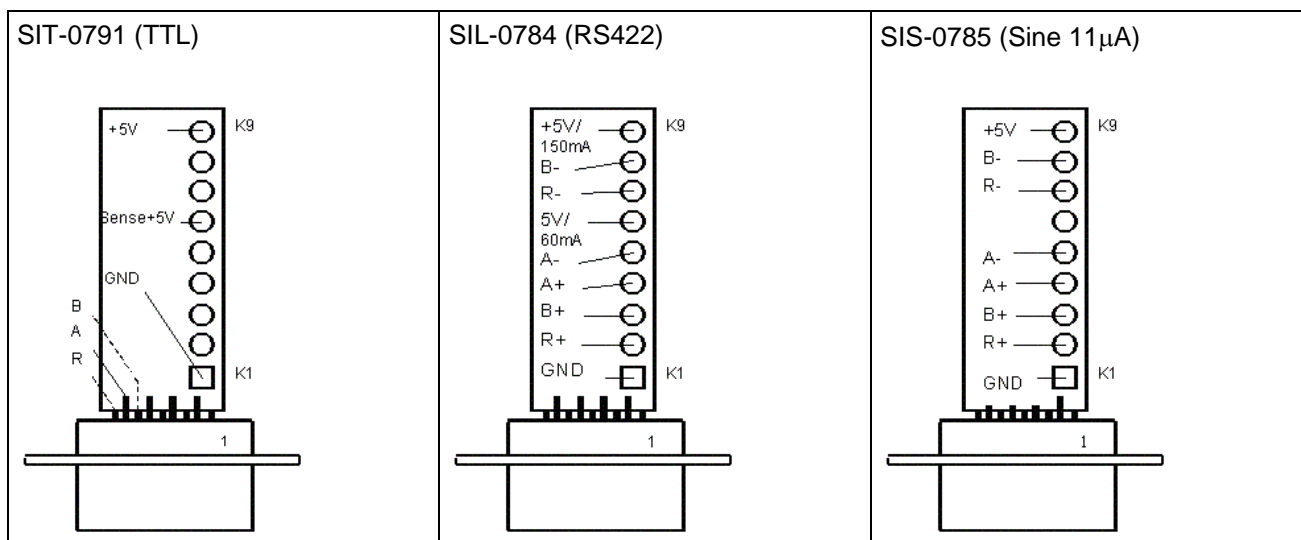

Fig. 14: Configuration of the soldering points of the old series of 9-pin incremental sensor plugs.

